

# TAILGATE DEFENDER

FORD F150 YEARS 2015-PRESENT

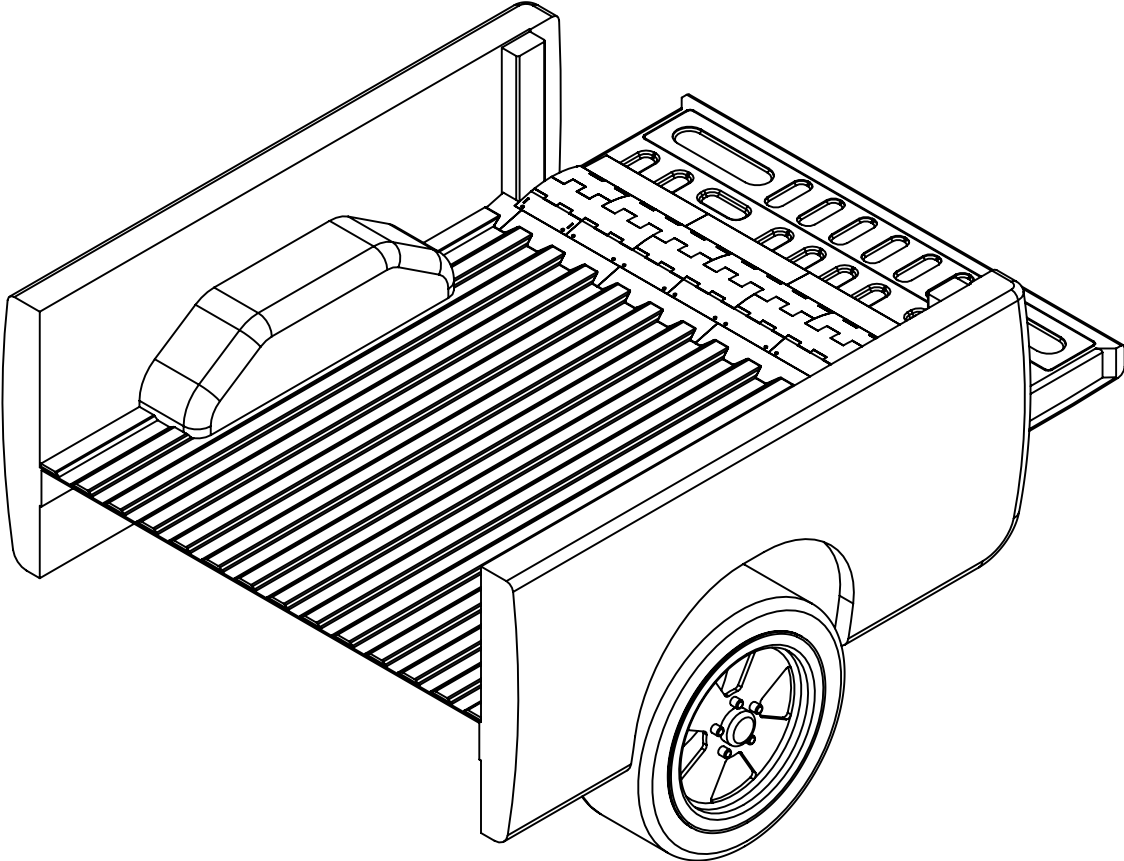

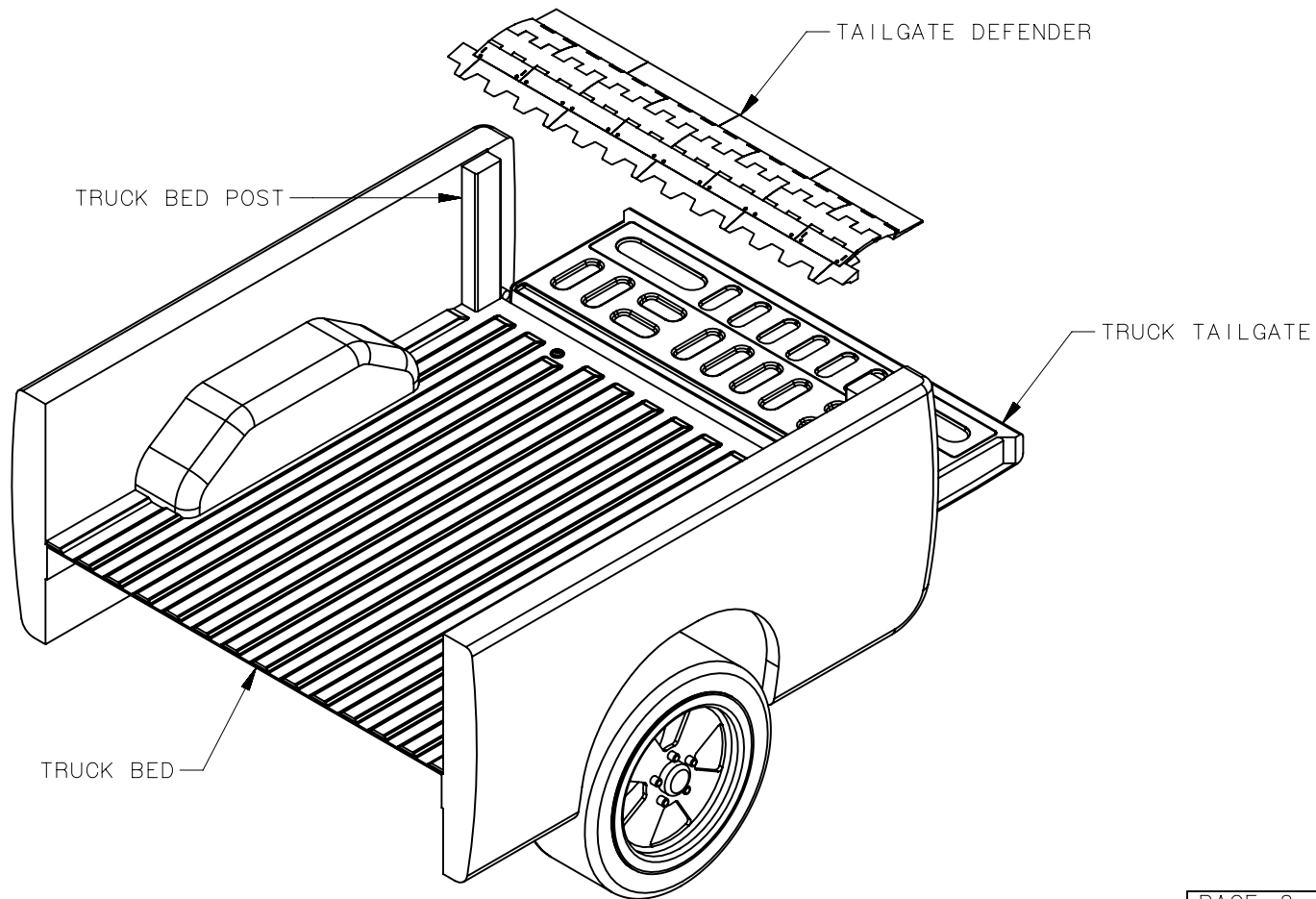

# STEP 1 - ASSEMBLE BED MOLDING PARTS:

- A) LAYOUT THE BED MOLDING PARTS WITH THE BOTTOM SIDE FACING UP.
- B) ATTACH (4) 1 (BED MOLDINGS), (1) 2 (LH CORNER BED MOLDING)  
(1) 3 (RH CORNER BED MOLDING) TOGETHER WITH (5) 10 (SCREWS).

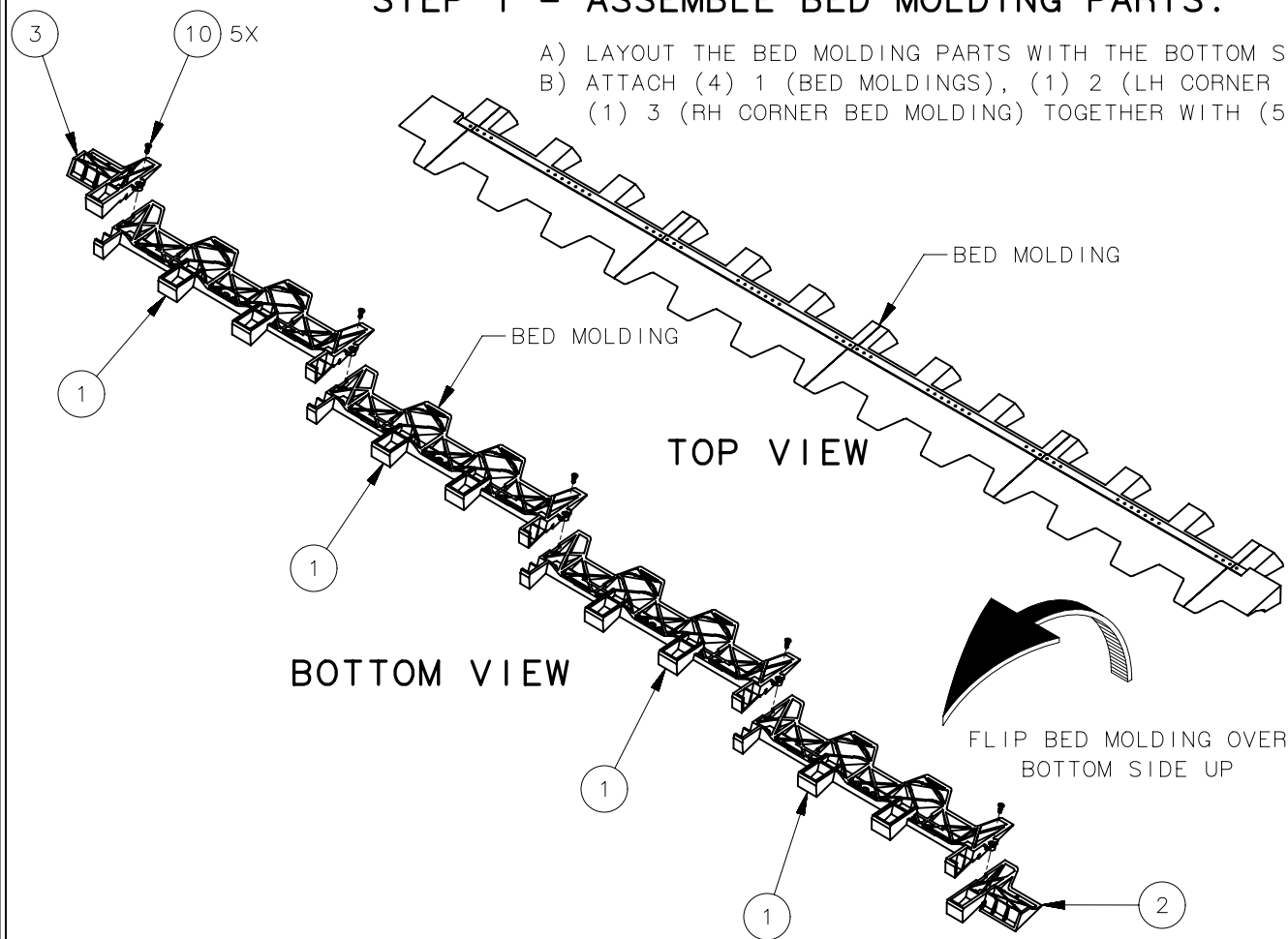

## STEP 2 - ATTACH LINK #1 TO BED MOLDING:

- A) ATTACH (3) 4 (LINKS) AND (2) 5 (LH AND RH LINKS)  
TOGETHER WITH (16) 10 (SCREWS).

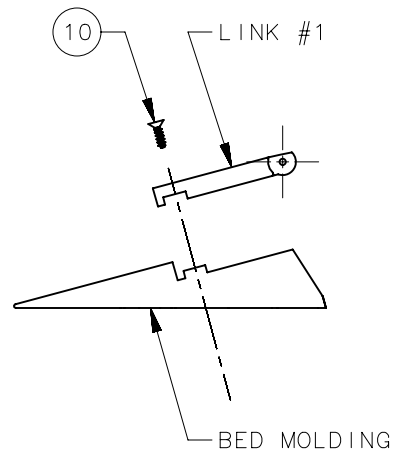
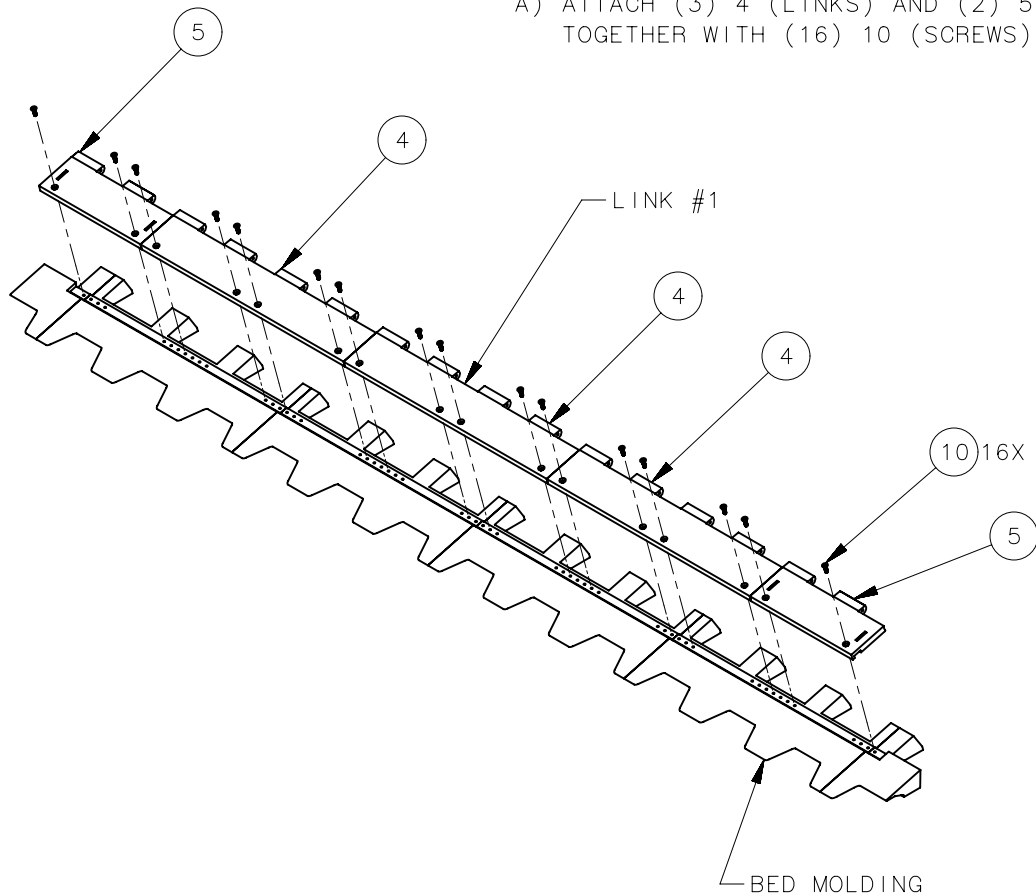

## STEP 3 - ATTACH LINK #2 TO LINK #1:

- A) FROM LH SIDE DRIVE (3) 9 (PINS) THRU LINK #1 & LINK #2 HOLES.
- B) FROM RH SIDE DRIVE (2) 9 (PINS) THRU LINK #1 & LINK #2 HOLES.

**CAUTION: DO NOT USE A HAMMER TO INSTALL THE PINS. MAKE SURE THE HOLES ARE ALIGNED AS THE PINS ARE BEING INSTALLED.**

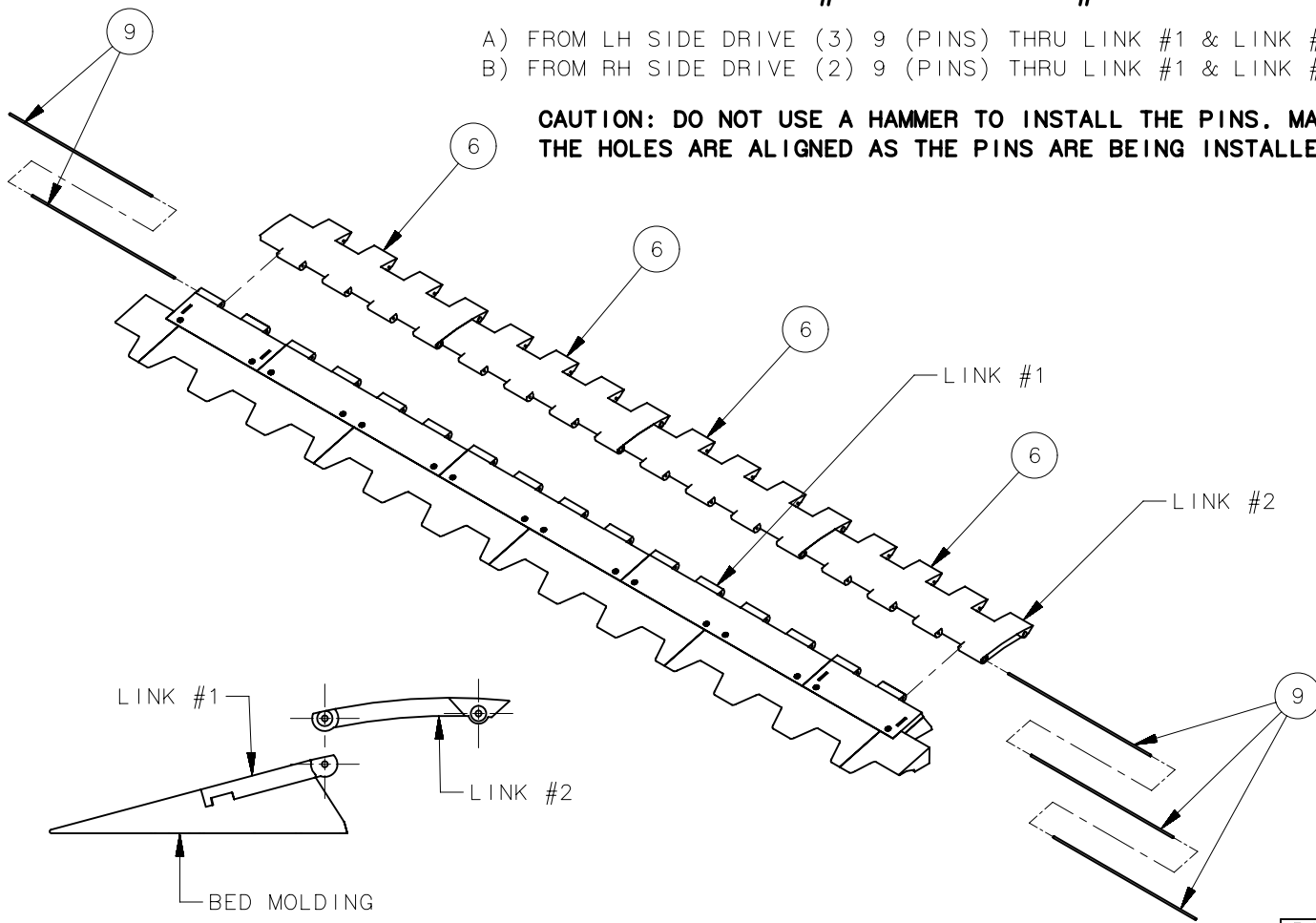

## STEP 4 - ATTACH LINK #3 TO LINK #2:

- A) ROTATE LINK #3 180 DEGREES OPPOSING LINK #2.
- B) FROM LH SIDE DRIVE (3) 9 (PINS) THRU LINK #2 & LINK #3 HOLES.
- C) FROM RH SIDE DRIVE (2) 9 (PINS) THRU LINK #2 & LINK #3 HOLES.

**CAUTION: DO NOT USE A HAMMER TO INSTALL THE PINS. MAKE SURE THE HOLES ARE ALIGNED AS THE PINS ARE BEING INSTALLED.**

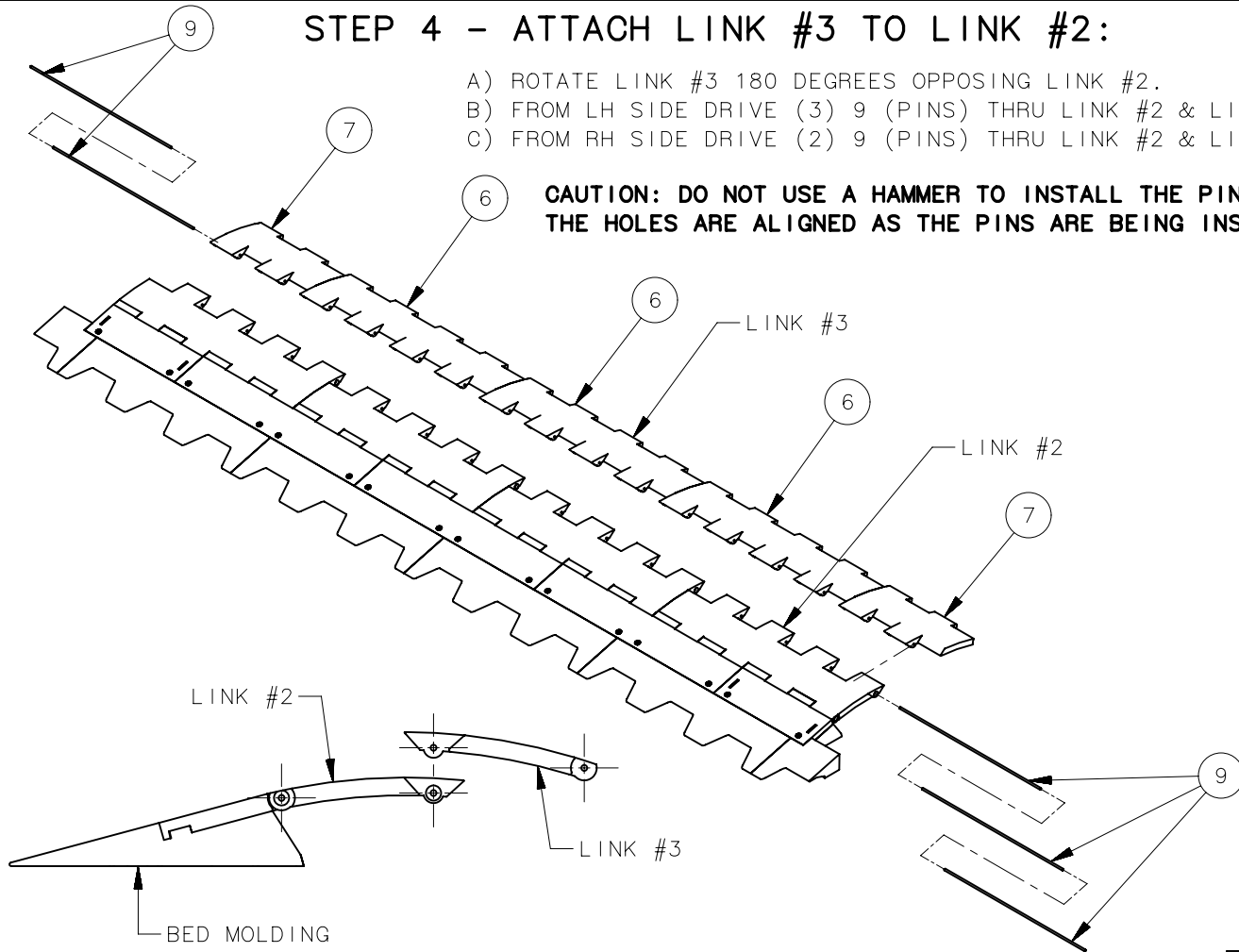

## STEP 5 - ATTACH TAILGATE MOLDING TO LINK #3:

- A) FROM LH SIDE DRIVE (3) 9 (PINS) THRU TAILGATE MOLDING & LINK #3 HOLES.
- B) FROM RH SIDE DRIVE (2) 9 (PINS) THRU TAILGATE MOLDING & LINK #3 HOLES.

**CAUTION: DO NOT USE A HAMMER TO INSTALL THE PINS. MAKE SURE THE HOLES ARE ALIGNED AS THE PINS ARE BEING INSTALLED.**

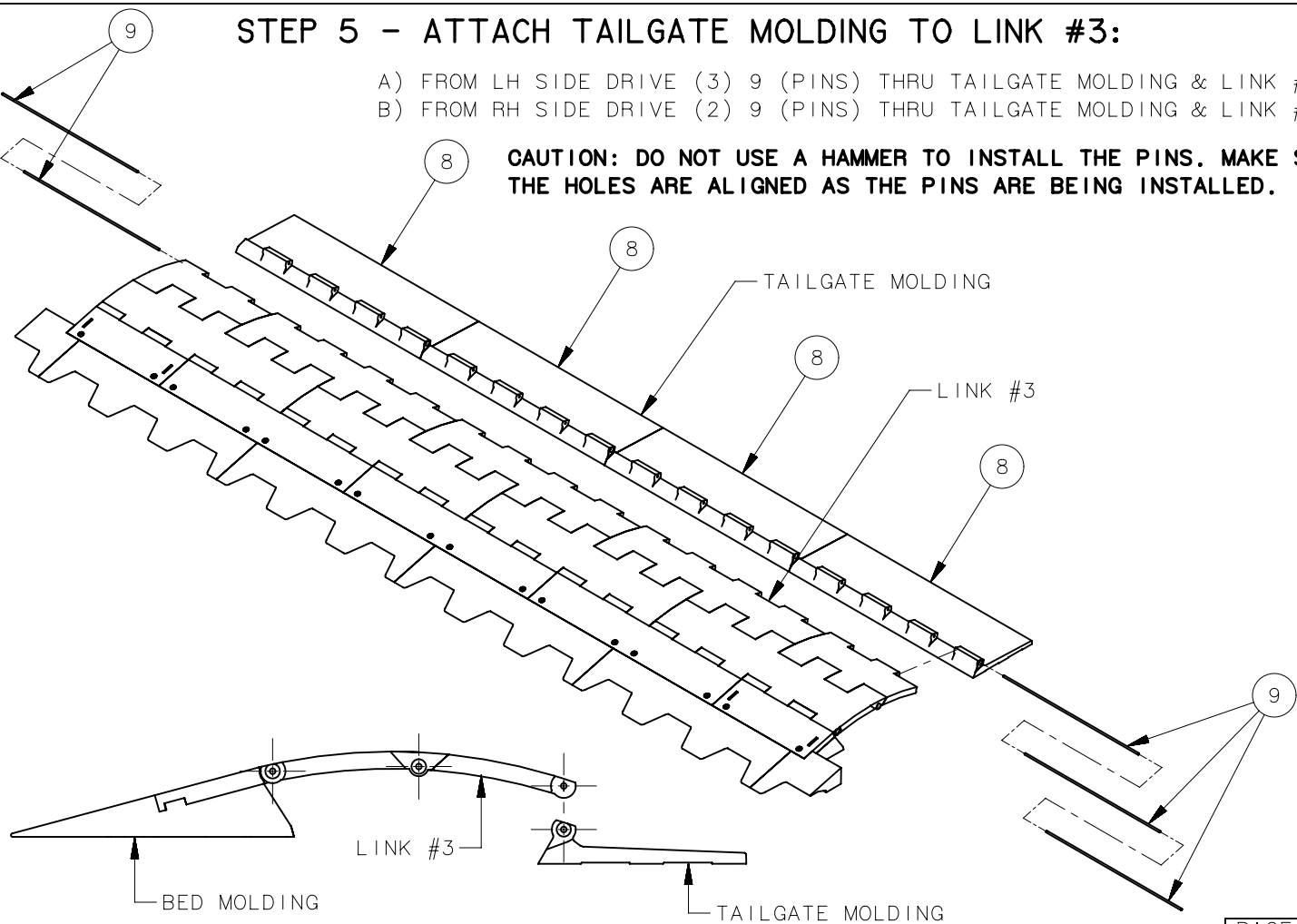

## STEP 6 - COMPLETING THE TAILGATE DEFENDER:

- A) DRIVE THE PINS APPROXIMATELY 1/2 DEEP ON BOTH ENDS.
- B) FROM LH SIDE INSTALL (3) 10 (SCREWS).
- C) FROM RH SIDE INSTALL (3) 10 (SCREWS).

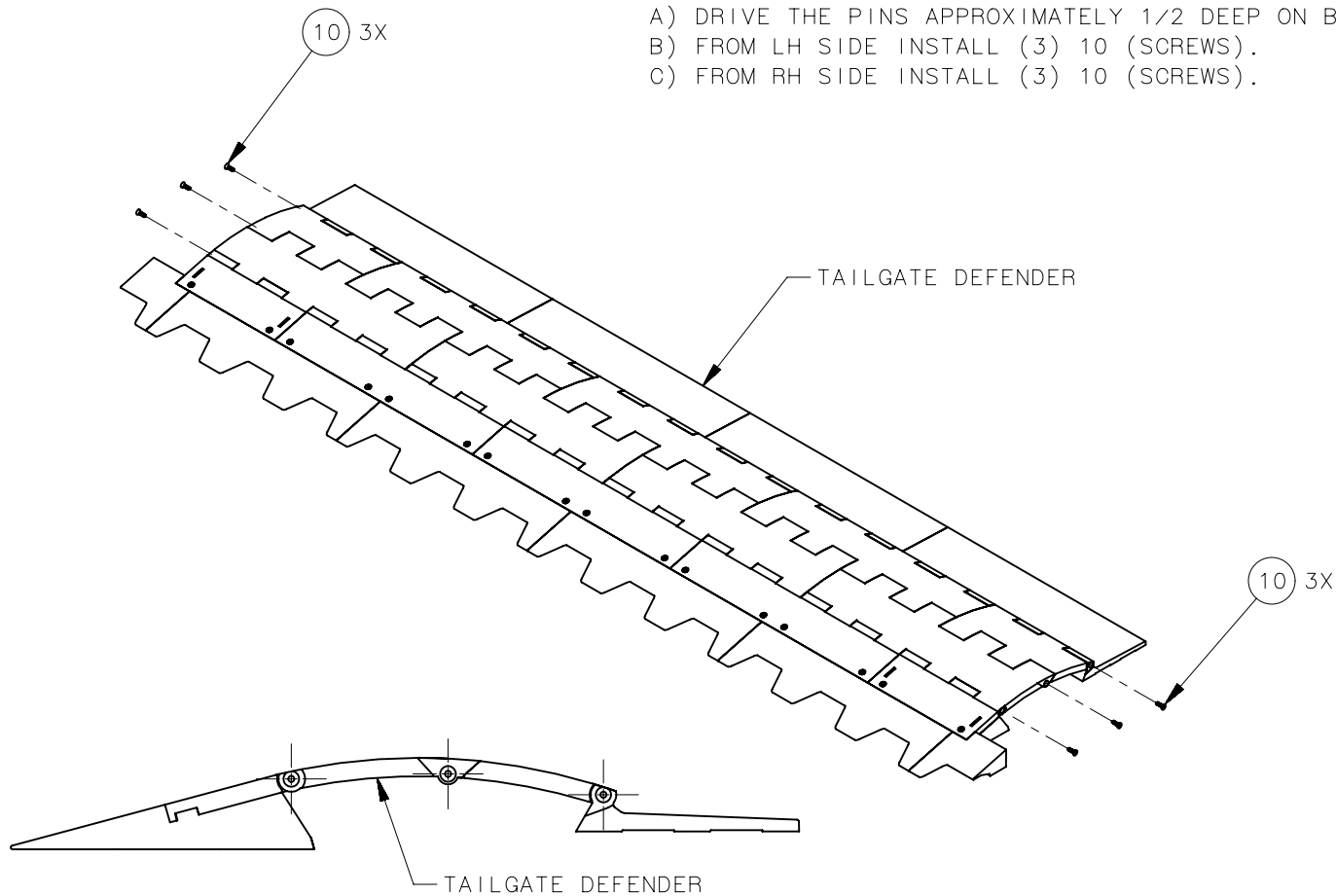



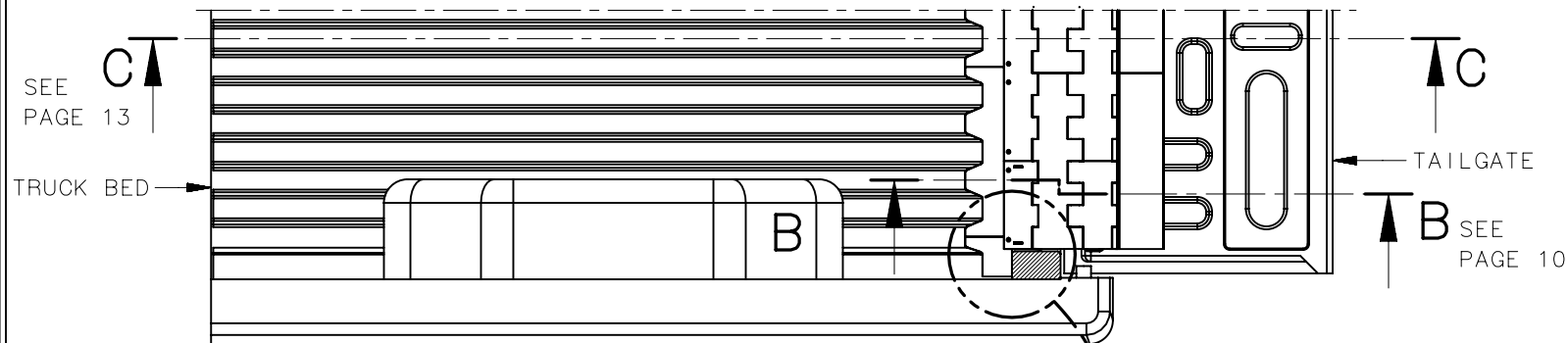

## STEP 7 - INSTALLING THE TAILGATE DEFENDER:

- A) FULLY OPEN THE TRUCK TAILGATE.
- B) LOCATE THE TAILGATE DEFENDER AS SHOWN.
- C) PEEL OFF THE BED MOLDING TAPE FILM. (SEE NEXT PAGE)  
(DO NOT APPLY TAPE TO TRUCK BED)
- D) INDEX THE BED MOLDING TO THE FORWARD SIDE OF THE BED POST AS SHOWN.
- E) MAKE THE LH & RH GAP EQUAL BETWEEN LINK #1 & THE BED POST.
- F) APPLY BED MOLDING TAPE TO TRUCK BED.
- G) PEEL OFF THE TAILGATE MOLDING TAPE FILM.
- H) APPLY TAILGATE MOLDING TO TRUCK TAILGATE.
- J) APPLY SILICONE THE FULL LENGTH BETWEEN BED MOLDING & TRUCK BED.

NOTE: FOR A MORE PERMANENT APPLICATION REMOVE ALL TAPE AND USE SILICONE ADHESIVE TO APPLY TAILGATE DEFENDER TO TRUCK BED AND TAILGATE.

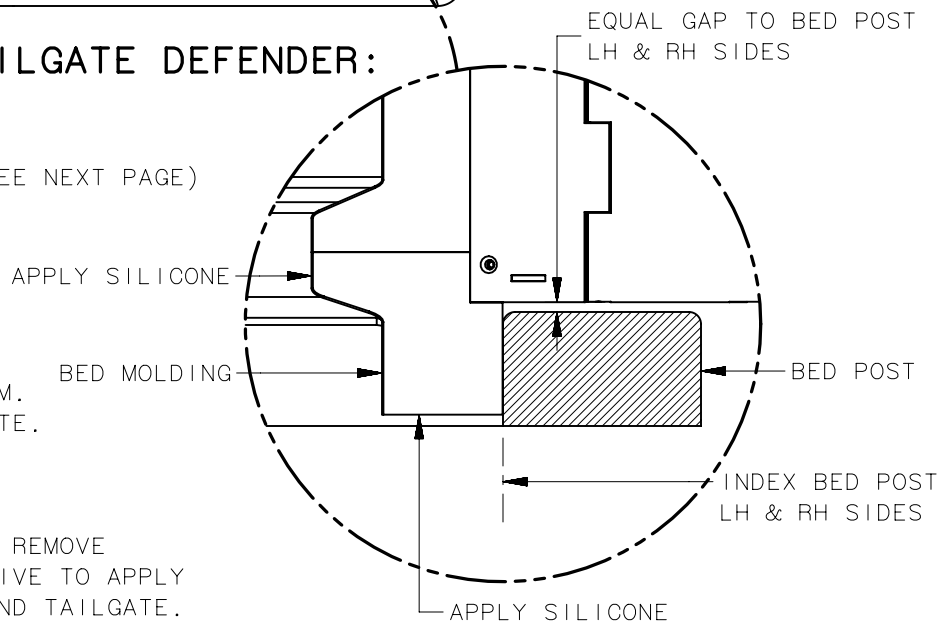

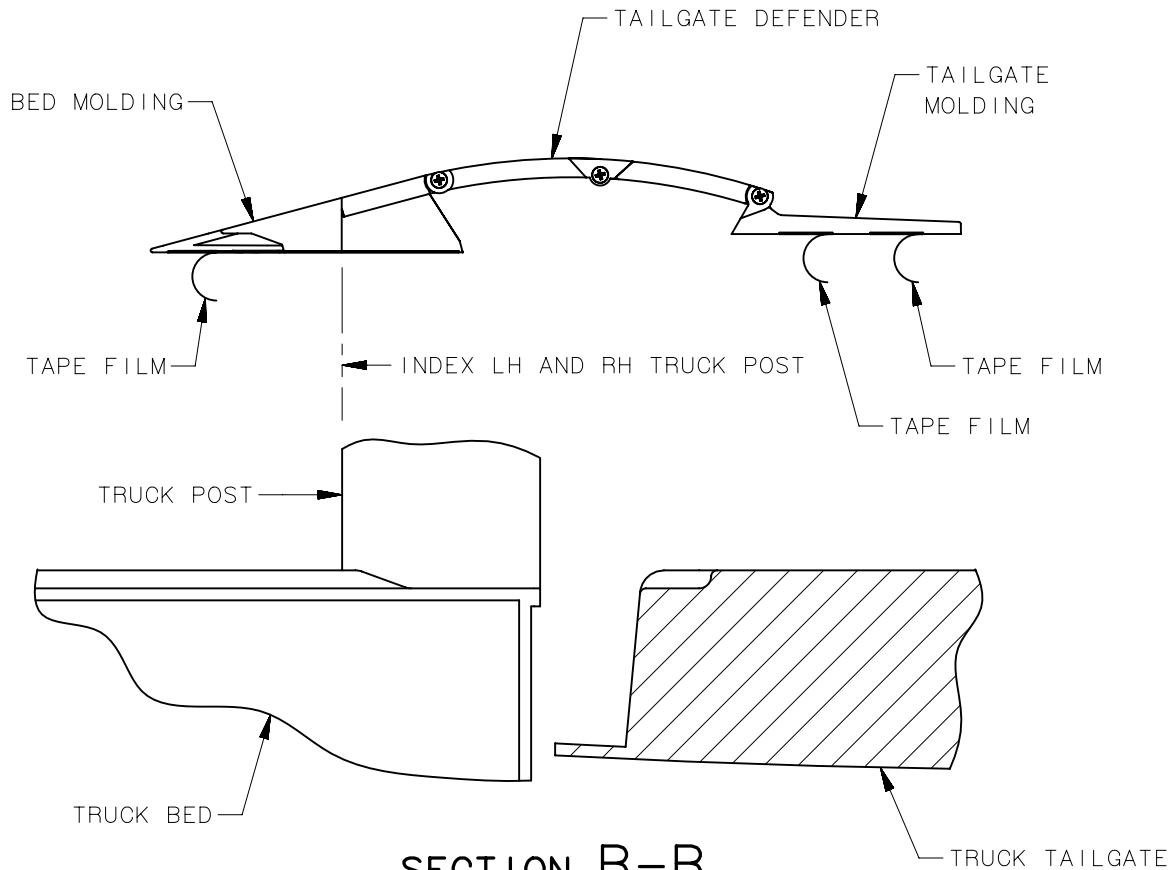



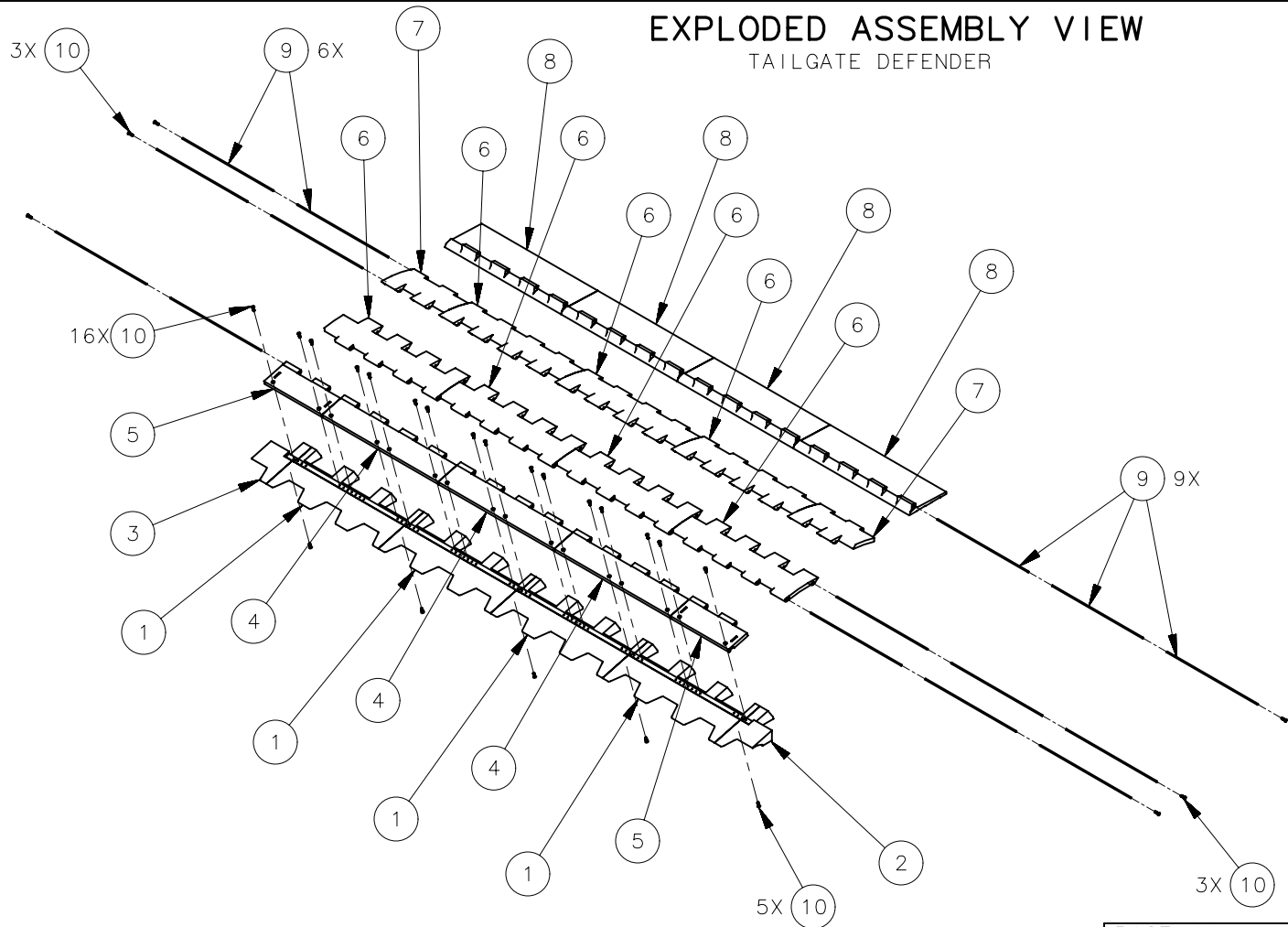

**SECTION B-B**  
 SEE PAGE 9

# EXPLODED ASSEMBLY VIEW

TAILGATE DEFENDER

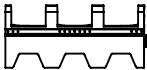

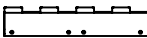
## PARTS LIST

PART	QTY	DESCRIPTION
	(4)	1 BED MOLDING
	(1)	2 BED MOLDING ((LEFT HAND (LH) CORNER BED MOLDING))
	(1)	3 BED MOLDING ((RIGHT HAND (RH) CORNER BED MOLDING))
	(3)	4 LINK #1 (FULL SIZE)
	(2)	5 LINK #1 ((LEFT HAND (LH) AND RIGHT HAND (RH) HALF SIZE))
	(7)	6 LINK #2 AND #3 (FULL SIZE)
	(2)	7 LINK #3 (HALF SIZE)
	(4)	8 TAILGATE MOLDING
	(15)	9 PINS
	(27)	10 SCREWS

## TOOLS REQUIRED

PHILLIPS SCREW DRIVER

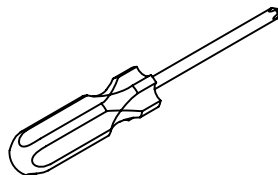

CAULK GUN

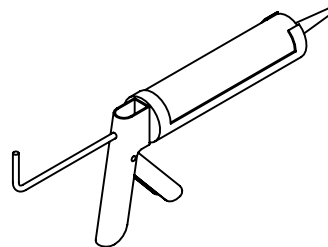

# LOADING OPTIONS

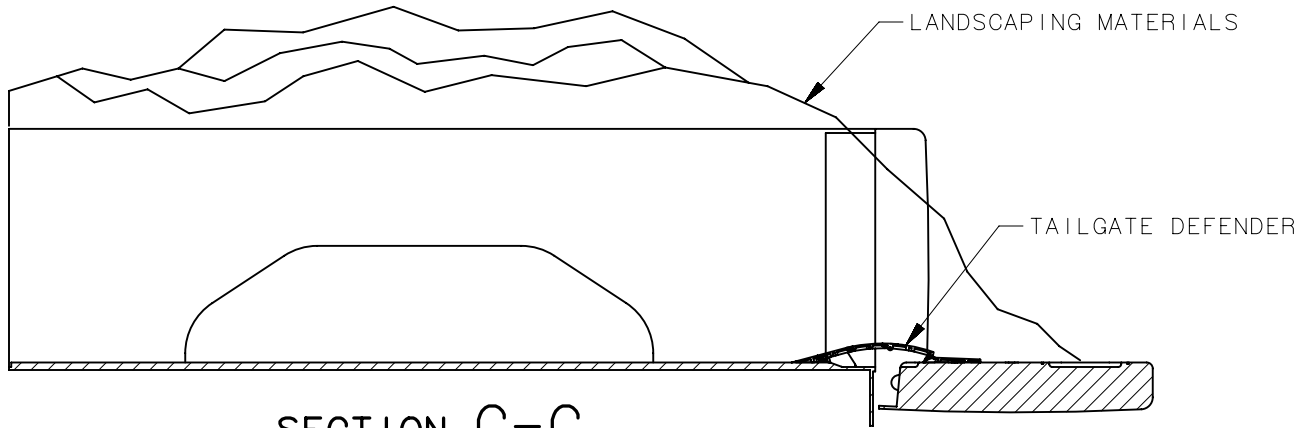

SECTION C-C  
OPEN TAILGATE

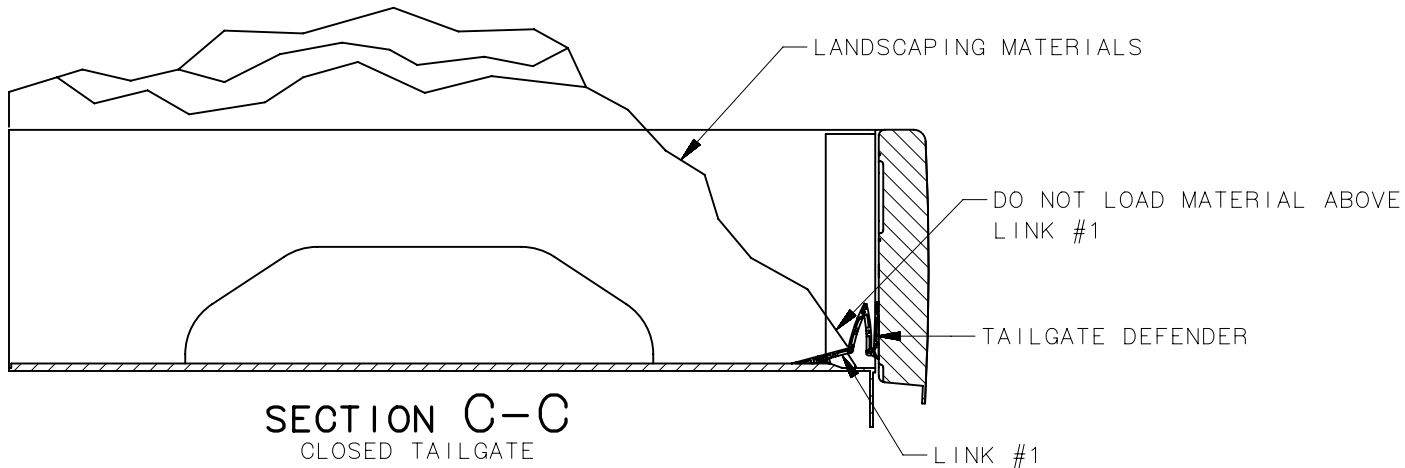

SECTION C-C  
CLOSED TAILGATE